

1550nm DFB ITU Butterfly Laser Diode



Power 1-70mW, SM, PM, width<5MHz, integrated with isolator and monitor

DATASHEET

[Return to the Webpage](#)

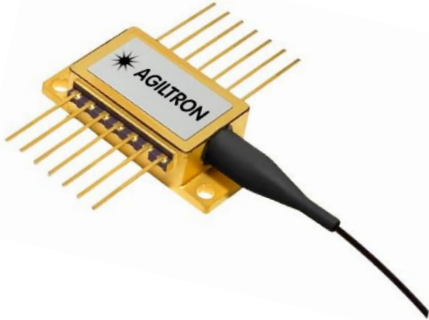

Features

- Built-in Optical Isolator
- Low Capacitance
- High Stability of DFB Structure
- Integrated Tap Monitor

Applications

- Instrument
- Analog/Digital Transmission



The DFBI series fiber-coupled laser diodes are designed with a GaAs quantum well structure integrated with a grating that matches the ITU grids. These diodes feature a built-in isolator for preventing back reflection induced emission instability and a photodiode for precise monitoring and feedback control of the laser's output power. Housed in standard 14 pin packages, these diodes are pigtailed to a 1-meter long single-mode fiber terminated with an FC/APC connector. Each unit undergoes rigorous testing prior to shipment to ensure reliability. Additionally, we offer cost-effective, high-performance feedback control drivers that maintains constant and adjustable output power, along with an externally cooled mounting fixture to stabilize the output wavelength. It is available in benchtop, and module or driver kit for convenient integration.

This laser is configured for direct analog/digital modulation with frequencies up to 1.5GHz.

Specifications

Parameter	Min	Typical	Max	Unit
Operating Case Temperature	-20		65	°C
Storage Temperature	-40		70	°C
Laser Forward Current	-		250	mA
Laser Reverse Bias	-		2	V
Threshold Current	-	5	15	mA
Photodiode Reverse Bias	-		10	V
Monitor Dark Current	-	-	100	nA
Thermistor Resistance	9.5	-	10.5	KΩ
Thermistor B Constant		3900		K
TEC Current	-2		+2	A
TEC Voltage	-2.5		+2.5	V
Thermistor Temperature	-20		65	°C
ESD	-500		+500	V
Lead Solder Temperature	-		260	°C
Lead Soldering Time	-		10	S
Environmental Operating Humidity	-		95	%
Environmental Storage Humidity	-		95	%
Fiber Bend Radius	-		20	mm
Fiber Yield Strength	-		1	kgf
Optical & Electrical Characteristics				
Center Wavelength	1520	1550	1575	nm
Spectral Width (-20dB)	-		5	MHz
Modulation Speed DC			1.5	GHz
Optical Output Power	1		70	mW
Optical Isolation	30	35	-	dB
Side-mode Suppression Ratio	40	50	-	dB
Polarization Extinction Ratio (PER)	20			dB
Relative Intensity Noise			-145	dB/Hz
Wavelength Drift		-	±0.1	nm
Wavelength Temperature Coefficient			0.09	nm/°C
Wavelength Current Coefficient			0.01	nm/mA

Rev 11/06/24

© Photonwares Corporation

+1 781-935-1200

sales@photonwares.com

www.agiltron.com

Information contained herein is deemed to be reliable and accurate as of the issue date. Photonwares reserves the right to change the design or specifications at any time without notice. Agiltron is a registered trademark of Photonwares Corporation in the U.S. and other countries.

1550nm DFB ITU Butterfly Laser Diode



Power 1-70mW, SM, PM, width<5MHz, integrated with isolator and monitor

DATASHEET

Mechanical Dimension (mm)

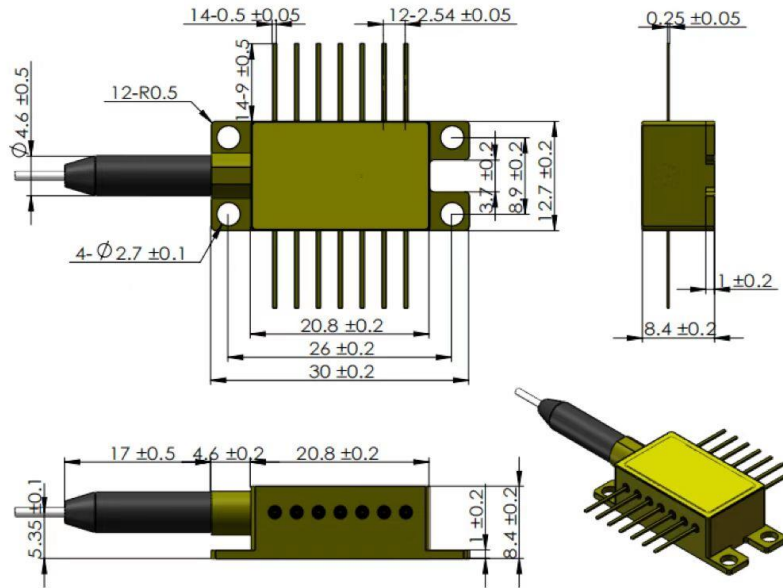

*Product dimensions may change without notice. This is sometimes required for non-standard specifications.

PIN Assignment

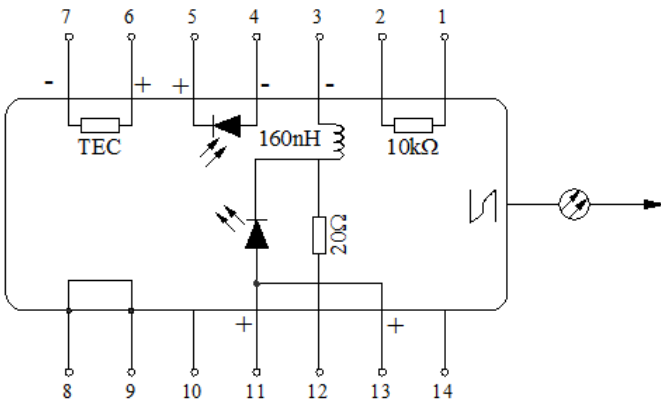

PIN	Function
1	Thermistor
2	Thermistor
3	Laser dc Bias (Cathode) (-)
4	Monitor PD Anode (-)
5	Monitor PD Cathode (+)
6	Thermoelectric Cooler (+)
7	Thermoelectric Cooler (-)
8	Case Ground
9	Case Ground
10	NC
11	Laser Anode (+)
12	Laser RF Cathode (-)
13	Laser Anode (+)
14	NC

1550nm DFB ITU Butterfly Laser Diode



Power 1-70mW, SM, PM, width<5MHz, integrated with isolator and monitor

DATASHEET

Analog High-Speed Modulation Response (10MHz to 3GHz)

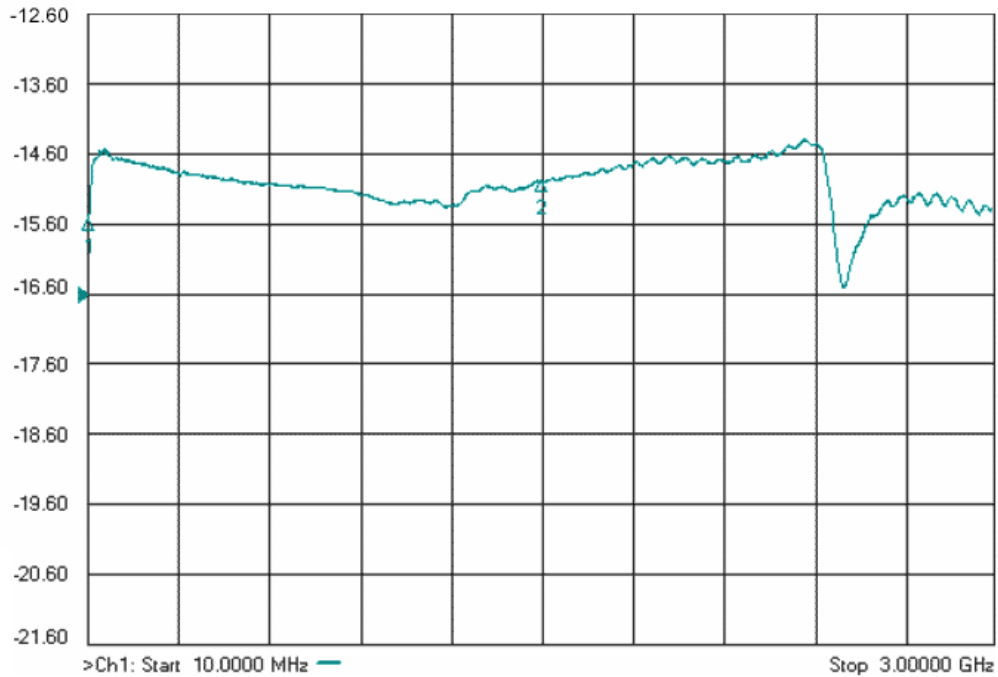

1550nm DFB ITU Butterfly Laser Diode



Power 1-70mW, SM, PM, width<5MHz, integrated with isolator and monitor

DATASHEET

Typical Spectrum

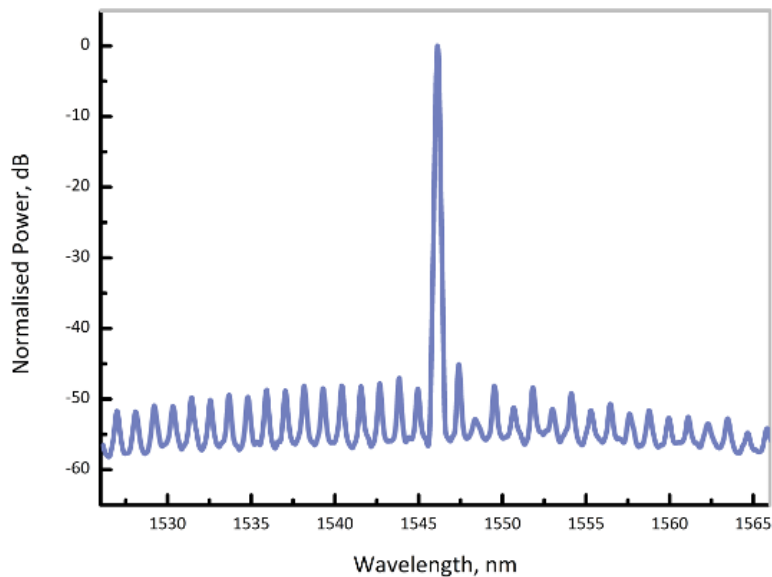

Ordering Information

Prefix	Wavelength	Power	PD	Fiber Type	Fiber Buffer	Fiber Length	Connector
DFBI-	Select From Table Channel Name	1mW = 01 5mW = 05 10mW = 10 20mW = 20 30mW = 30 40mW = 40 50mW = 50 60mW = 60 70mW = 70 80mW = 80	None = 1 Yes = 2	SM28 = 1 PM1550 = 5 Special = 0	0.9mm Tube = 3 Special = 0	1.0m = 3 0.25m = 1 0.5 m = 2 1.5 m = 5 Special = 0	FC/APC = 3 FC/PC = 2 Non = 1 SC/PC = 4 SC/APC = 5 LC/PC = 7 LC/UPC = U Special = 0

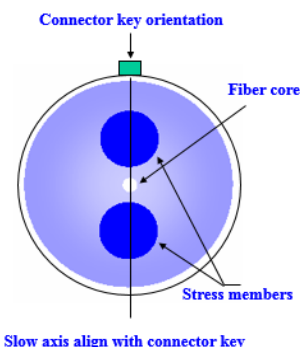

1550nm DFB ITU Butterfly Laser Diode



Power 1-70mW, SM, PM, width<5MHz, integrated with isolator and monitor

DATASHEET

Wavelength Selection

C63	1527.02	1527.22	1527.42	nm	C43	1542.74	1542.94	1543.14	nm
H62	1527.40	1527.60	1527.80	nm	H42	1543.13	1543.33	1543.53	nm
C62	1527.79	1527.99	1528.19	nm	C42	1543.53	1543.73	1543.93	nm
H61	1528.18	1528.38	1528.58	nm	H41	1543.93	1544.13	1544.33	nm
C61	1528.57	1528.77	1528.97	nm	C41	1544.33	1544.53	1544.73	nm
H60	1528.96	1529.16	1529.36	nm	H40	1544.72	1544.92	1545.12	nm
C60	1529.35	1529.55	1529.75	nm	C40	1545.12	1545.32	1545.52	nm
H59	1529.74	1529.94	1530.14	nm	H39	1545.52	1545.72	1545.92	nm
C59	1530.13	1530.33	1530.53	nm	C39	1545.92	1546.12	1546.32	nm
H58	1530.52	1530.72	1530.92	nm	H38	1546.32	1546.52	1546.72	nm
C58	1530.92	1531.12	1531.32	nm	C38	1546.72	1546.92	1547.12	nm
H57	1531.31	1531.51	1531.71	nm	H37	1547.12	1547.32	1547.52	nm
C57	1531.70	1531.90	1532.10	nm	C37	1547.52	1547.72	1547.92	nm
H56	1532.09	1532.29	1532.49	nm	H36	1547.91	1548.11	1548.31	nm
C56	1532.48	1532.68	1532.88	nm	C36	1548.31	1548.51	1548.71	nm
H55	1532.87	1533.07	1533.27	nm	H35	1548.71	1548.91	1549.11	nm
C55	1533.27	1533.47	1533.67	nm	C35	1549.12	1549.32	1549.52	nm
H54	1533.66	1533.86	1534.06	nm	H34	1549.52	1549.72	1549.92	nm
C54	1534.05	1534.25	1534.45	nm	C34	1549.92	1550.12	1550.32	nm
H53	1534.44	1534.64	1534.84	nm	H33	1550.32	1550.52	1550.72	nm
C53	1534.84	1535.04	1535.24	nm	C33	1550.72	1550.92	1551.12	nm
H52	1535.23	1535.43	1535.63	nm	H32	1551.12	1551.32	1551.52	nm
C52	1535.62	1535.82	1536.02	nm	C32	1551.52	1551.72	1551.92	nm
H51	1536.02	1536.22	1536.42	nm	H31	1551.92	1552.12	1552.32	nm
C51	1536.41	1536.61	1536.81	nm	C31	1552.32	1552.52	1552.72	nm
H50	1536.80	1537.00	1537.20	nm	H30	1552.73	1552.93	1553.13	nm
C50	1537.20	1537.40	1537.60	nm	C30	1553.13	1553.33	1553.53	nm
H49	1537.59	1537.79	1537.99	nm	H29	1553.53	1553.73	1553.93	nm
C49	1537.99	1538.19	1538.39	nm	C29	1553.93	1554.13	1554.33	nm
H48	1538.38	1538.58	1538.78	nm	H28	1554.34	1554.54	1554.74	nm
C48	1538.78	1538.98	1539.18	nm	C28	1554.74	1554.94	1555.14	nm
H47	1539.17	1539.37	1539.57	nm	H27	1555.14	1555.34	1555.54	nm
C47	1539.57	1539.77	1539.97	nm	C27	1555.55	1555.75	1555.95	nm
H46	1539.96	1540.16	1540.36	nm	H26	1555.95	1556.15	1556.35	nm
C46	1540.36	1540.56	1540.76	nm	C26	1556.35	1556.55	1556.75	nm
H45	1540.75	1540.95	1541.15	nm	H25	1556.76	1556.96	1557.16	nm
C45	1541.15	1541.35	1541.55	nm	C25	1557.16	1557.36	1557.56	nm
H44	1541.55	1541.75	1541.95	nm	H24	1557.57	1557.77	1557.97	nm
C44	1541.94	1542.14	1542.34	nm	C24	1557.97	1558.17	1558.37	nm
H43	1542.34	1542.54	1542.74	nm	H23	1558.38	1558.58	1558.78	nm

1550nm DFB ITU Butterfly Laser Diode



Power 1-70mW, SM, PM, width<5MHz, integrated with isolator and monitor

DATASHEET

Wavelength Selection

C23	1558.78	1558.98	1559.18	nm
H22	1559.19	1559.39	1559.59	nm
C22	1559.59	1559.79	1559.99	nm
H21	1560.00	1560.20	1560.40	nm
C21	1560.41	1560.61	1560.81	nm
H20	1560.81	1561.01	1561.21	nm
C20	1561.22	1561.42	1561.62	nm
H19	1561.63	1561.83	1562.03	nm
C19	1562.03	1562.23	1562.43	nm
H18	1562.44	1562.64	1562.84	nm
C18	1562.85	1563.05	1563.25	nm
H17	1563.25	1563.45	1563.65	nm
C17	1563.66	1563.86	1564.06	nm
H16	1564.07	1564.27	1564.47	nm
C16	1564.48	1564.68	1564.88	nm
H15	1564.89	1565.09	1565.29	nm
C15	1565.30	1565.50	1565.70	nm
H14	1565.70	1565.90	1566.10	nm
C14	1566.11	1566.31	1566.51	nm
H13	1566.52	1566.72	1566.92	nm
C13	1566.93	1567.13	1567.33	nm
H12	1567.34	1567.54	1567.74	nm
C12	1567.75	1567.95	1568.15	nm
H11	1568.16	1568.36	1568.56	nm
C11	1568.57	1568.77	1568.97	nm
H10	1568.98	1569.18	1569.38	nm
C10	1569.39	1569.59	1569.79	nm
H09	1569.81	1570.01	1570.21	nm
C09	1570.22	1570.42	1570.62	nm
H08	1570.63	1570.83	1571.03	nm
C08	1571.04	1571.24	1571.44	nm
H07	1571.45	1571.65	1571.85	nm
C07	1571.86	1572.06	1572.26	nm
H06	1572.28	1572.48	1572.68	nm
C06	1572.69	1572.89	1573.09	nm
H05	1573.10	1573.30	1573.50	nm
C05	1573.51	1573.71	1573.91	nm
H04	1573.93	1574.13	1574.33	nm
C04	1574.34	1574.54	1574.74	nm
H03	1574.75	1574.95	1575.15	nm

C03	1575.17	1575.37	1575.57	nm
H02	1575.58	1575.78	1575.98	nm
C02	1576.00	1576.20	1576.40	nm
H01	1576.41	1576.61	1576.81	nm
C01	1576.83	1577.03	1577.23	nm
Q00	1577.24	1577.44	1577.64	nm
L00	1577.66	1577.86	1578.06	nm
Q99	1578.07	1578.27	1578.47	nm
L99	1578.49	1578.69	1578.89	nm
Q98	1578.90	1579.10	1579.30	nm
L98	1579.32	1579.52	1579.72	nm
Q97	1579.73	1579.93	1580.13	nm
L97	1580.15	1580.35	1580.55	nm
Q96	1580.57	1580.77	1580.97	nm
L96	1580.98	1581.18	1581.38	nm
Q95	1581.40	1581.60	1581.80	nm
L95	1581.82	1582.02	1582.22	nm
Q94	1582.24	1582.44	1582.64	nm
L94	1582.65	1582.85	1583.05	nm
Q93	1583.07	1583.27	1583.47	nm
L93	1583.49	1583.69	1583.89	nm
Q92	1583.91	1584.11	1584.31	nm
L92	1584.33	1584.53	1584.73	nm
Q91	1584.75	1584.95	1585.15	nm
L91	1585.16	1585.36	1585.56	nm
Q90	1585.58	1585.78	1585.98	nm
L90	1586.00	1586.20	1586.40	nm
Q89	1586.42	1586.62	1586.82	nm
L89	1586.84	1587.04	1587.24	nm
Q88	1587.26	1587.46	1587.66	nm
L88	1587.68	1587.88	1588.08	nm
Q87	1588.10	1588.30	1588.50	nm
L87	1588.53	1588.73	1588.93	nm
Q86	1588.95	1589.15	1589.35	nm
L86	1589.37	1589.57	1589.77	nm
Q85	1589.79	1589.99	1590.19	nm
L85	1590.21	1590.41	1590.61	nm
Q84	1590.63	1590.83	1591.03	nm
L84	1591.06	1591.26	1591.46	nm
Q83	1591.48	1591.68	1591.88	nm

1550nm DFB ITU Butterfly Laser Diode



Power 1-70mW, SM, PM, width<5MHz, integrated with isolator and monitor

DATASHEET

Wavelength Selection

L83	1591.90	1592.10	1592.30	nm
Q82	1592.32	1592.52	1592.72	nm
L82	1592.75	1592.95	1593.15	nm
Q81	1593.17	1593.37	1593.57	nm
L81	1593.59	1593.79	1593.99	nm
Q80	1594.02	1594.22	1594.42	nm
L80	1594.44	1594.64	1594.84	nm
Q79	1594.86	1595.06	1595.26	nm
L79	1595.29	1595.49	1595.69	nm
Q78	1595.71	1595.91	1596.11	nm
L78	1596.14	1596.34	1596.54	nm
Q77	1596.56	1596.76	1596.96	nm
L77	1596.99	1597.19	1597.39	nm
Q76	1597.42	1597.62	1597.82	nm
L76	1597.84	1598.04	1598.24	nm
Q75	1598.27	1598.47	1598.67	nm
L75	1598.69	1598.89	1599.09	nm
Q74	1599.12	1599.32	1599.52	nm
L74	1599.55	1599.75	1599.95	nm
Q73	1599.97	1600.17	1600.37	nm
L73	1600.40	1600.60	1600.80	nm
Q72	1600.83	1601.03	1601.23	nm
L72	1601.26	1601.46	1601.66	nm
Q71	1601.68	1601.88	1602.08	nm
L71	1602.11	1602.31	1602.51	nm
Q70	1602.54	1602.74	1602.94	nm
L70	1602.97	1603.17	1603.37	nm
Q69	1603.40	1603.60	1603.80	nm
L69	1603.83	1604.03	1604.23	nm
Q68	1604.26	1604.46	1604.66	nm
L68	1604.68	1604.88	1605.08	nm
Q67	1605.11	1605.31	1605.51	nm
L67	1605.54	1605.74	1605.94	nm
Q66	1605.97	1606.17	1606.37	nm
L66	1606.40	1606.60	1606.80	nm
Q65	1606.84	1607.04	1607.24	nm
L65	1607.27	1607.47	1607.67	nm
Q64	1607.70	1607.90	1608.10	nm
L64	1608.13	1608.33	1608.53	nm
Q63	1608.56	1608.76	1608.96	nm
L63	1608.99	1609.19	1609.39	nm
Q62	1609.42	1609.62	1609.82	nm
L62	1609.86	1610.06	1610.26	nm
Q61	1610.29	1610.49	1610.69	nm
L61	1610.72	1610.92	1611.12	nm

1550nm DFB ITU Butterfly Laser Diode



Power 1-70mW, SM, PM, width<5MHz, integrated with isolator and monitor

DATASHEET

Benchtop Matching Laser Diode Driver



Agiltron cost-effective LDCB series benchtop control kit is designed for easy laser diode mounting and precise control. It incorporates a high-precision, low-noise auto-feedback drive electronics to ensure constant output power or a constant driving current and an integrated temperature control unit maintains optimal operating conditions. The system provides up to 1A driving current and up to 2A TEC cooling current. Each system features a front fiber output connector. The user interface includes an intuitive LCD display for independent control of output power and temperature via two front rotating knobs. The LDCB also includes a universal power supply compatible with 100 to 240 VAC. The LDCB has a built-in isolator option to prevent reflection-induced laser emissions instability. The LDCB is designed as a laser diode and TEC controller kit for customer to install laser diode. It has three types of pluggable laser mounts of butterfly, DIL, and TOCAN. The TOCAN mount contains an external TEC that maintains a constant temperature for wavelength stability.

For details please click: <https://agiltron.com/product/laser-diode-tec-controllers-benchtop-kit/>

Turn-Key Module Matching The Laser Diode



The Agiltron LDCM series laser source module is designed for OEM applications and features all-in-one high reliability and highly stable laser output. The LDCM contains high-precision, low-noise, auto-feedback laser diode drive electronics to ensure constant output power or driving current and an integrated temperature controller that maintains optimal operating conditions. An optional fiber optical isolator can be integrated to prevent reflection-induced laser emission instability, which is essential for achieving highly stable lasers. Agiltron produces isolators from 370nm to 2600nm. The system provides up to 1A driving current and up to 2A TEC cooling current. Each unit features a single FC/APC connector output and two front rotating knobs for independent setting of laser output power and temperature. A toggle switch allows selection between constant current control mode and feedback constant output power mode.

For details please click: <https://agiltron.com/product/laser-diode-tec-controllers-module/>

Laser Driver Kit



Agiltron cost-effective LDCD series module control kit is designed for easy laser diode mounting and precise control. It incorporates a high-precision, low-noise auto-feedback drive electronics to ensure constant output power or a constant driving current and an integrated temperature control unit maintains optimal operating conditions. The system provides up to 1A driving current and up to 2A TEC cooling current. It has three types of pluggable laser mounts of butterfly, DIL, and TOCAN. The TOCAN mount contains an external TEC that maintains a constant temperature for wavelength stability. It comes with cables to connect between the mounting module to the driving module, making integration convenient.

For details please click: <https://agiltron.com/product/laser-diode-tec-controllers-compact/>

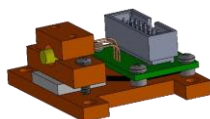
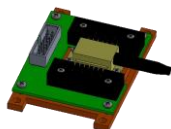

1550nm DFB ITU Butterfly Laser Diode



Power 1-70mW, SM, PM, width<5MHz, integrated with isolator and monitor

DATASHEET

Caution Electrostatic Sensitivity



- Never touch laser diode and the module using hands
- Always use protections when handle a laser diode
- Recommend mounting the laser diode using an ionic gun and ESD finger cots



Laser Safety

This product meets the appropriate standard in Title 21 of the Code of Federal Regulations (CFR). FDA/CDRH Class 1M laser product. This device has been classified with the FDA/CDRH under accession number 0220191. All versions of this laser are Class 1M laser products, tested according to IEC 60825-1:2007 / EN 60825-1:2007. An additional warning for Class 1M laser products. For diverging beams, this warning shall state that viewing the laser output with certain optical instruments (for example eye loupes, magnifiers, and microscopes) within a distance of 100 mm may pose an eye hazard. For collimated beams, this warning shall state that viewing the laser output with certain instruments designed for use at a distance (for example telescopes and binoculars) may pose an eye hazard.

Wavelength = 1.3/1.5 μm .

Maximum power = 30 mW.



*Caution - Use of controls or adjustments or performance of procedures other than those specified herein may result in hazardous radiation exposure.

*IEC is a registered trademark of the International Electrotechnical Commission.